

(19) World Intellectual Property Organization  
International Bureau



(43) International Publication Date  
23 May 2002 (23.05.2002)

PCT

(10) International Publication Number  
WO 02/40365 A1

- (51) International Patent Classification<sup>7</sup>: **B65D 39/00**
- (21) International Application Number: PCT/US01/51251
- (22) International Filing Date: 29 October 2001 (29.10.2001)
- (25) Filing Language: English
- (26) Publication Language: English
- (30) Priority Data:  
09/715,688 17 November 2000 (17.11.2000) US
- (71) Applicant: **SEAQUIST CLOSURES FOREIGN, INC.** [US/US]; 475 West Terra Cotta, Crystal Lake, IL 60014 (US).
- (72) Inventors: **WOOD, Christopher, J.**; 2900 S. 60th Street, Milwaukee, WI 53219 (US). **ROBERTS, Charles, E.**; S94 W34310 Jericho Drive, Eagle, WI 53119 (US). **DALLAS, Milton, R., Jr.**; 1739 Thomas Drive, East Troy, WI 53120 (US).
- (74) Agents: **ODELL, Paul, M.** et al.; Wood, Philips, Katz, Clark & Mortimer, Citicorp Center, Suite 3800, 500 West Madison Street, Chicago, IL 60661-2511 (US).
- (81) Designated States (*national*): AU, BR, CA, CN, CZ, IN, JP, MX, PL, RU.
- (84) Designated States (*regional*): European patent (AT, BE, CH, CY, DE, DK, ES, FI, FR, GB, GR, IE, IT, LU, MC, NL, PT, SE, TR).
- Published:**  
— with international search report  
— before the expiration of the time limit for amending the claims and to be republished in the event of receipt of amendments
- For two-letter codes and other abbreviations, refer to the "Guidance Notes on Codes and Abbreviations" appearing at the beginning of each regular issue of the PCT Gazette.*

(54) Title: ELASTOMERIC HINGE FOR A CLOSURE LID

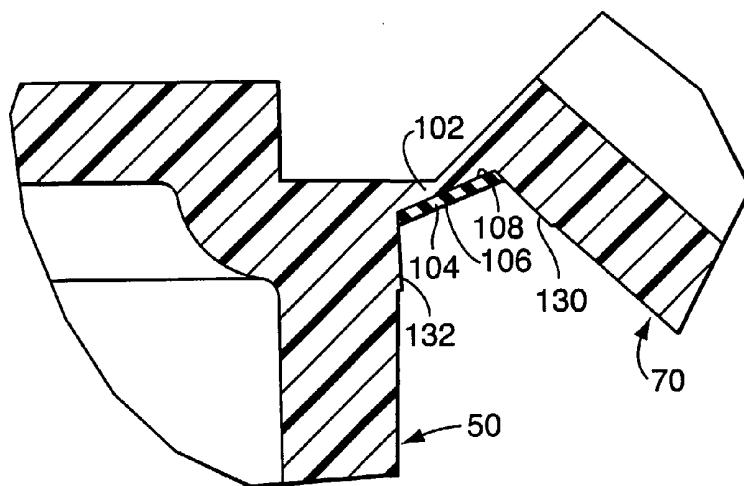

(57) Abstract: A hinge structure (80, 80A, 80B) is provided for connecting two members (50, 70; 50A, 70A; 50B, 70B), such as a container closure base (50, 50A, 50B) and lid (70, 70A, 70B), so as to accommodate movement between an open position and a closed position. An elastomeric element (104, 104A, 104B) extends from one of the members to the other of the members. The elastomeric element (104, 104A, 104B) has an outer surface that is outwardly exposed when the two members are in the closed position as well as when the two members are in the open position. The elastomeric element (104, 104A, 104B) exerts a force to urge the two members from the closed position toward the open position. In one embodiment, the elastomeric element has two lateral margins (121, 122; 121A, 122A; 121B, 122B), and the hinge structure (80, 80A, 80B) is free of structure laterally of the elastomeric element (104, 104A, 104B) so that the two lateral margins are laterally exposed when the two members are in the closed position as well as when the two members are in the open position. The elastomeric element outer surface (106, 106A, 106B) is in tension when the two members are in the closed position.



WO 02/40365 A1